

C50DC | BATH Ventilation

Cyclone[®]
Breathe Better

Ventilation Fan

Cyclone is proud to introduce the all-new C50DC bath ventilation fan, innovatively designed to be the absolute quietest bath fan on the market at its size. Protect your home and keep it feeling fresh by efficiently ventilating all of the moisture and odour from your bathrooms. Outstanding value, perfect for small to midsize bathrooms.



Features

- DC motor
- 50 CFM
- 2.0 sones
- Includes 3" duct connector
- Recommended for bathrooms up to 45 sqft (8' ceiling)

Housing

- Wiring from inside or outside housing with 8" leads
- 26 gauge galvanized steel housing (corrosion resistant)

Installation

- Mounted with flange
- 3" diameter duct connectors supplied
- Premium grille made of rugged polymeric resin for durability & comes with torsion spring clips for even mounting



Cyclone Range Hoods Inc.

1361 Huntingwood Drive, Unit 16. Toronto, ON. M1S 3J1. Canada.

Toll Free: 1-888-293-5662 Tel: (416) 293-0933 Fax: (416) 293-4793 Website: www.CycloneRangeHoods.com

C50DC | BATH Ventilation

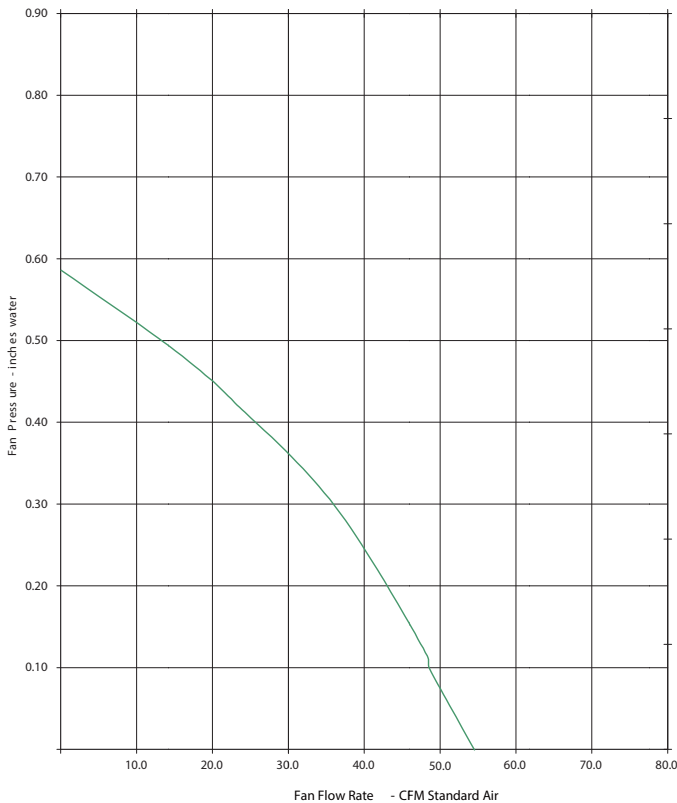

SPECIFICATIONS	C50DC
Static Pressure	0.1
Noise Level (Sones)	2.0
Air Flow Volume (CFM)	50
Current (Amps)	0.1
Power Consumption (Watts)	10
Electrical Connection (V/Hz)	120/60
Thermal Fuse Protection	Yes
Motor Type	DC
Blower Wheel	Centrifugal
Duct Diameter	3"

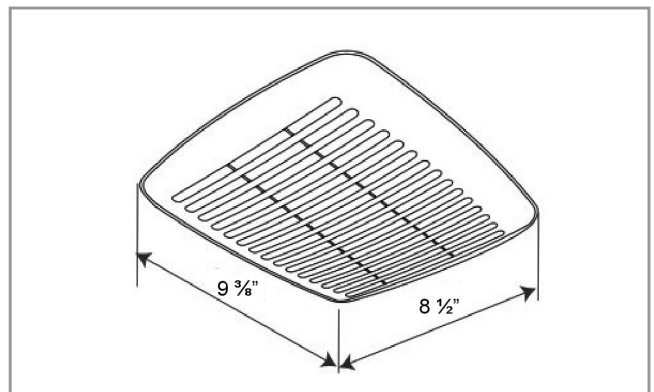
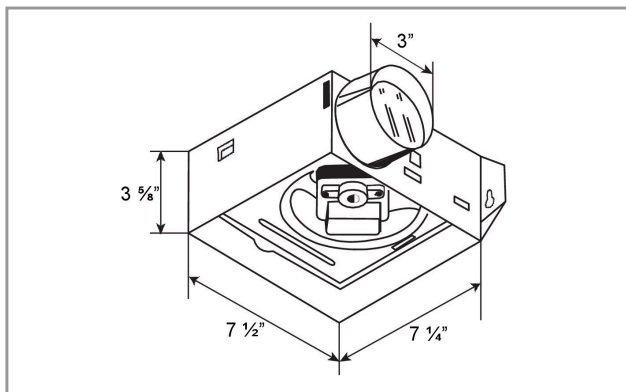

Model	Description	Packaging	Contractor Pack	Master Pack
C50DC	Bathroom Ventilation	Individual	-	Pack of 12
C50DC MBG	50 CFM Motor/Blade/Grille	-	Pack of 6	-
C50 HSG	C50 CFM Housing	-	Pack of 6	-