

# BXB609 | PRO Collection



## Insert

Cyclone's newest insert, the BXB609 is discreet and quiet yet powerful enough to leave a distinct impression. Powered at 900 CFM it is well-suited for high heat cooking. Fitted with dishwasher safe stainless steel baffle filters. Comes equipped with three speeds push buttons and two bright LED lights for total control. The sleek BXB609 range hood cannot be seen from eye level, as it is designed to fit into your custom wood canopy.

## Green Features



3 Speed Push Button Control Panel



Dishwasher Safe Baffle Filters



Long-lasting LED Light Bulbs



Model	Colour	Ducting	Filters	Size	CFM	Fits Cabinet
BXB60934	Stainless Steel	8"	Baffle	34"	900	36"
BXB60940	Stainless Steel	8"	Baffle	40"	900	42"
BXB60946	Stainless Steel	8"	Baffle	46"	900	48"
BXB60934MB	Matte Black	8"	Baffle	34"	900	36"
BXB60940MB	Matte Black	8"	Baffle	40"	900	42"
BXB60946MB	Matte Black	8"	Baffle	46"	900	48"

### Cyclone Range Hoods Inc.

1361 Huntingwood Drive, Unit 16. Toronto, ON. M1S 3J1. Canada.

Toll Free: 1-888-293-5662 Tel: (416) 293-0933

Fax: (416) 293-4793 Website: [www.CycloneRangeHoods.com](http://www.CycloneRangeHoods.com)

## Features

- Insert range hood
- 8" round duct adapter
- Non-stick aluminum fan blades
- 3 speed push button control
- Quick release dishwasher-safe baffle filters
- LED lights (1.4W, 4000K), 3 lights for 34", 4 lights for 40" and 46"
- 3 minutes time-delay OFF feature
- Plug-in connection

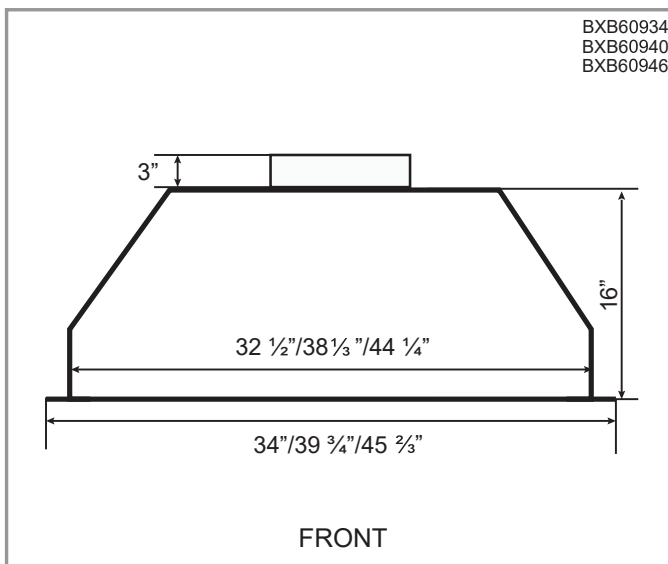
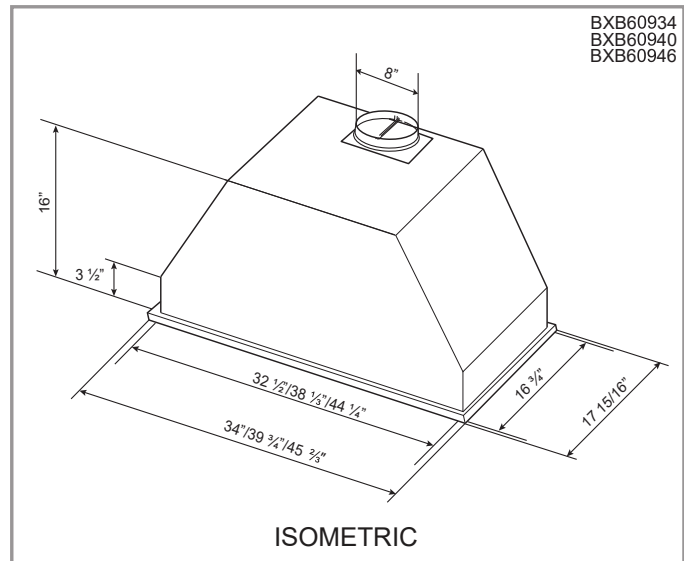

## Options

- Widths: 34", 40", 46"
- Finishes: Stainless Steel, Matte Black

## Specifications

- |                                                                                                                                                              |                                                                                                                                    |                                                                                                                                                                       |
|--------------------------------------------------------------------------------------------------------------------------------------------------------------|------------------------------------------------------------------------------------------------------------------------------------|-----------------------------------------------------------------------------------------------------------------------------------------------------------------------|
| <ul style="list-style-type: none"> <li>• Air Flow Volume: 900 CFM</li> <li>• Electrical Connection: 120 V/60 Hz</li> <li>• Power Consumption: TBD</li> </ul> | <ul style="list-style-type: none"> <li>• Current: TBD</li> <li>• Fan Speed: TBD</li> <li>• Fan Type: Centrifugal Blower</li> </ul> | <ul style="list-style-type: none"> <li>• Finishes: Stainless Steel, Matte Black</li> <li>• Ducting: 8" Round</li> <li>• Noise Level: Min. TBD<br/>Max. TBD</li> </ul> |
|--------------------------------------------------------------------------------------------------------------------------------------------------------------|------------------------------------------------------------------------------------------------------------------------------------|-----------------------------------------------------------------------------------------------------------------------------------------------------------------------|

